



**HEIMANN**  
FAHRZEUGBAU

**– Load and unload at ground level –**  
Quick, easy, and safe!

Lowerable trailer

**PT35/PT18**



Lowerable trailer



PT35 lowered down to the ground.



Trailer does not have to be unhitched for lowering.

## Trailers from Heimann

Our program is oriented towards **performance, robustness, and efficiency.**

Heimann trailers are manufactured down to the last detail using the highest quality construction elements.

**High quality materials** and **outstanding workmanship** offer longevity and a trailer that can handle heavy loads.

Exclusive **standard designs**, different models and the comprehensive **range of special accessories** demonstrate the synthesis of technical progress and the realization of useful ideas for the customer.

Numerous references speak for the quality we deliver and the satisfaction of our customers.

Just give us a call or come by and visit us. We would be happy to inform you in person about our range of products.

Karl Heimann  
Managing Director

## The advantages of the PT35 lowerable trailer

The PT35 lowerable trailer offers many advantages. Due to the ability to lower the trailer down to the ground, it is safe and easy to load the trailer. The loading area is raised and lowered using a manual pump. Thanks to the built-in rings on the floor of the trailer, it is easy to safety lash down the load.

### Manual pump

The manual pump hydraulically raises and lowers the loading area. Alternative: electro-hydraulic pump.

### Independent suspension

With hydraulic shock absorbers (Sachs suspension strut) for ideal driving comfort.

### Steel frame

The frame is hot-dip galvanized and therefore specially protected against rust through.

### Loading area height

Lowered, 80 mm.

### Drawbar

Rotatable bearings to allow lowering to the ground level while still on the towing vehicle.

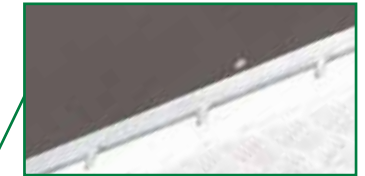

### Seamless transition

The tailgate has a seamless transition without an edge when driving on and off.

### Fastening rings

Fastening rings are built into the bed to secure the load.

### Tailgate

600 mm high, max. load capacity of 2500 kg depending on the design.

### Loading area

Loading area lowered hydraulically.





Loading with trolley.



PT35 with box body and with a with 45° angle in front in driving position.



Fast loading using lifting platforms.



Box body with tailgate that opens upwards.



Goods must be tightly and securely lashed to avoid potential hazards. Lashing rings built into the bed.



PT35 with box body, 2-rear wing doors, and tailgate lowered.

## The PT35 lowerable trailer

The PT35 lowerable trailer has a maximum permissible weight of 3,500 kg. The load capacity depends on the size of the trailer (max. load capacity up to 2,700 kg). The trailer can remain hitched to the vehicle while lowering and does not require any supports.

Due to the ability to lower it to 80 mm above **ground level**, there are completely new potential uses and loading possibilities. It is completely safe due to its very low ramp angle.

Inside dimensions:

Length: ..... 3,000 to 4,500 mm  
 Width: ..... 1,500 to 1,800 mm  
 Height: ..... 520 mm

Tarps, bows, box body, other dimensions and optional accessories available upon request

Other sizes and custom-made products available upon request.

## Lowerable trailers from Heimann Fahrzeugbau

Our lowerable trailers are easy to adapt to different requirements. Their handling was designed with safety in mind. All operating functions can be controlled centrally. We develop purpose-oriented ideas for you to obtain the easiest possible operation. The continuous development of our lowerable trailers is just as natural as the manufacturing of individual custom solutions.

Our lowerable trailers are highly flexible due their maneuverability and compact design. A large number of uses are possible due to its functionality and easy handling. High quality materials and outstanding workmanship provide longevity and a trailer that can handle heavy loads.

Ultra-modern technology and technical ingenuity make this lowerable trailer so unique. There are numerous advantages that make this product a top-of-the-line product. It is very easy and safe to load since it is not necessary to load it over a ramp. See for yourself!



The frame with raised side panels can be painted in various colors or powder-coated.

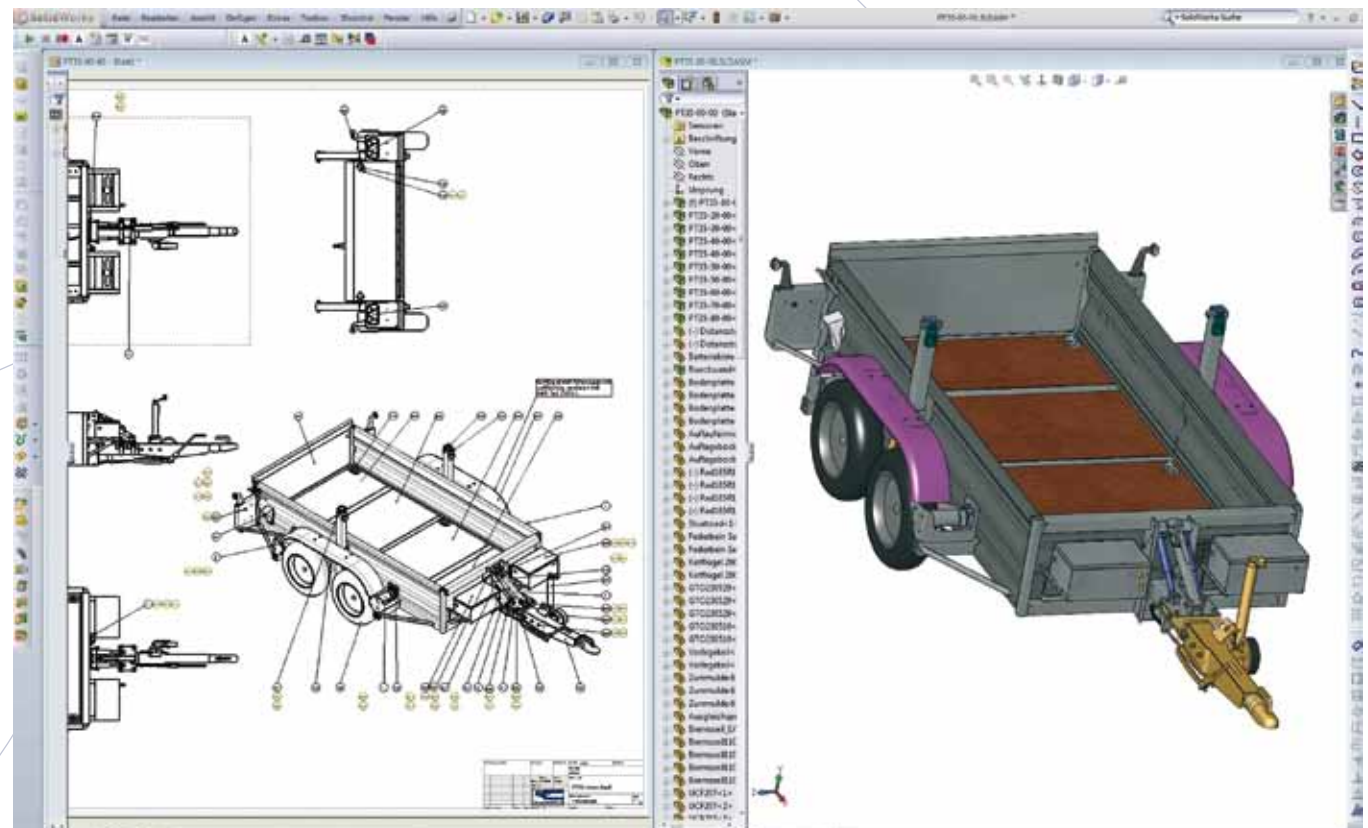

3-D construction to enable flexible configurations.



PT18 with polyurethane cover.



The PT18 with box body and 2-wing rear door.



When loading a cleaning machine, no damage to suction scrub brushes and guards.



The lowerable trailer PT18 when loading a vacuum sweeping machine.



The locking bar can be moved anywhere along the entire length of the trailer.



Easy to load the trailer using a hand truck.

## The PT18 lowerable trailer

The model **PT18** is another lowerable trailer available from Heimann. It is a single axle trailer with special advantages.

The PT18 has a maximum permissible weight of 1,800 kg. The load capacity depends on the size of the trailer (max. load capacity of up to 1,200 kg).

The **special suspension** offers ideal driving comfort due to an independent suspension and hydraulically operated coil springs.

Inside dimensions:

Length: ..... 2,500 to 3,500 mm  
 Width: ..... 1,300 to 1,800 mm  
 Height: ..... 520 mm

Tarps, bows, box body, other dimensions and optional accessories available upon request

Other sizes and custom-made products available upon request.

## The advantages of the PT18 lowerable trailer

The PT18 lowerable trailer has very special advantages. It can be lowered to the ground and is therefore safe and easy to load. The load can be secured and lashed down using the rings built into the bed. The trailer is raised and lowered via a hydraulic pump.

### Manual pump

The manual pump raises and lowers the loading area hydraulically. Alternative: electro-hydraulic pump.

### Steel frame

The frame is hot-dip galvanized and therefore specially protected against rust through.

### Fastening rings

Fastening rings are built into the bed to secure the load.

### Tailgate

600 mm high, max. loading capacity of 2500 kg depending on the design.

### Loading area height

Lowered, 80 mm.

### Drawbar

Rotatable bearings to allow lowering to the ground level while still on the towing vehicle.

### Independent suspension

With hydraulic shock absorbers (Sachs suspension strut) for ideal driving comfort, approved for use up to 100 km/h.



### Seamless transition

The tailgate has a seamless transition without an edge when driving on and off.

### Loading area

The loading area is lowered hydraulically.

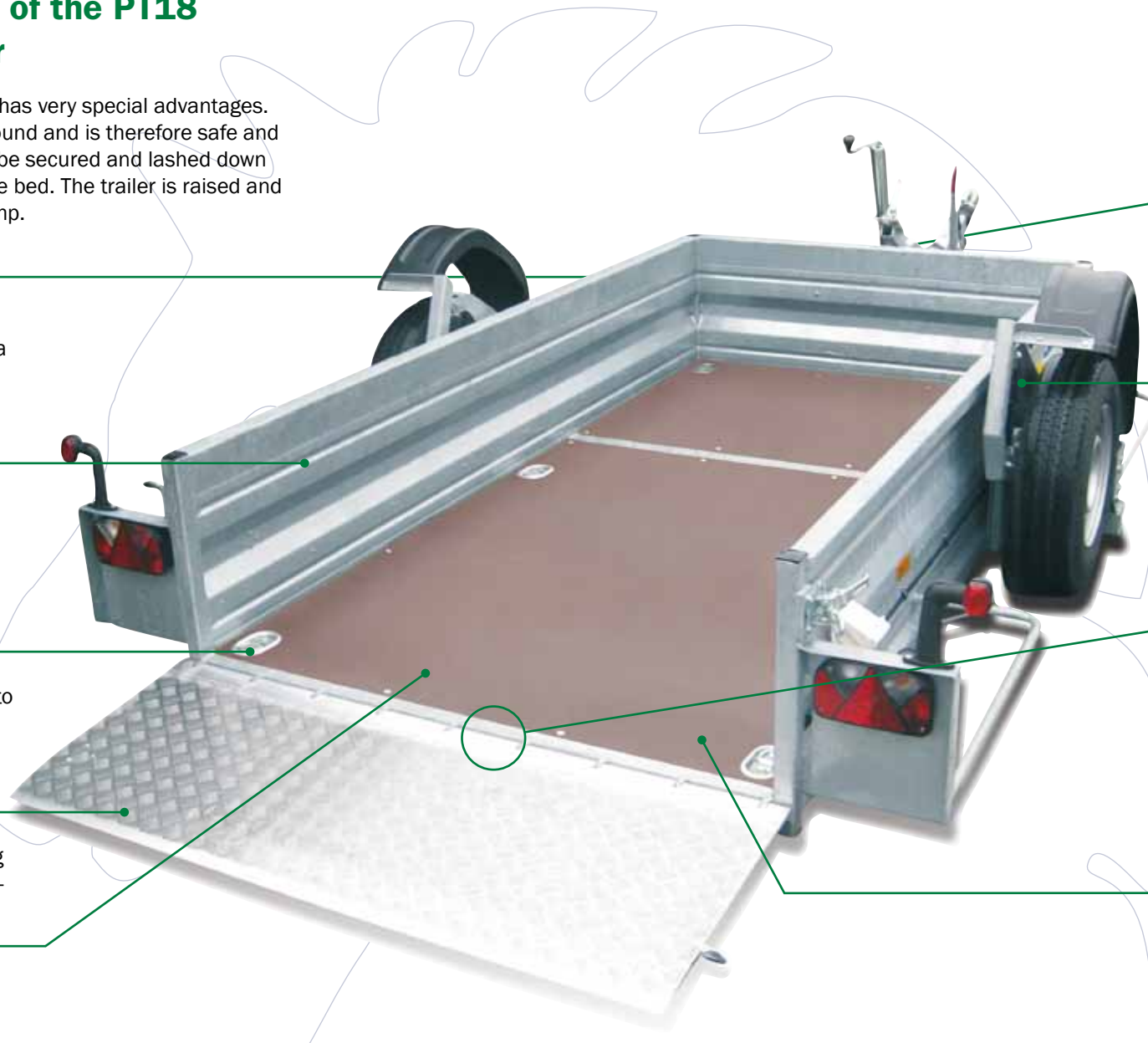



The locking lever is open at the front on the trailer hitch to lower the trailer.



Hand pump (standard equipment) with locking lever in locked position.



Bottom frame of the PT35 with multiplex wood panels.



Electrical pump with control unit.



Electro-hydraulic pump with emergency hand pump.

## Numerous optional accessories

Every area of application requires its own special equipment, which is why we offer numerous options for equipping the PT18 for the particular purpose. Regardless of whether you need load securing equipment, tarps, box bodies, or toolboxes – every trailer is custom-manufactured especially for you.

Even if you should need other kinds of accessories, we will find a solution for you.

Give us a call!





Control unit for the electric pump on the rear.



Loading with multi-track vehicles.



Transporting a steel roller compactor made easy.



Battery with charger (230 volt).



Motorcycle transporter.



Loading a vibrating compactor.



Trailer being loaded by a fork lift.



Loading a sweeping machine.



Loading a vacuum scrubbing machine.



Partition bar for clamping to the tarp frame.



Airline track with tie ring mounted on top of side panel or on top inside of side panel.



Lifting aid on tailgate.



Inside view of box with locking beams.



2 Airline tracks on the side with plastic load protector.



Storage boxes made of aluminum, plastic, or steel.



Raised side panel for partition bar.



Perforated bar with telescoping bar and floor ring.



Spare tire with holder.

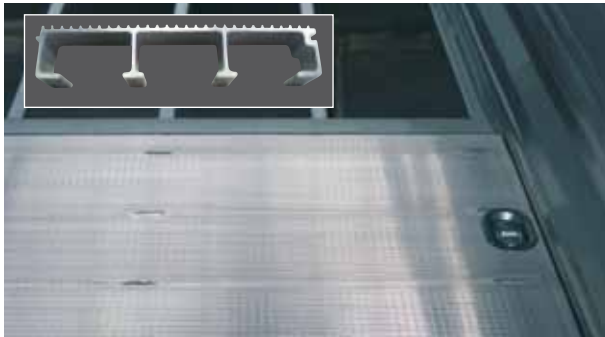

Aluminum floor without wood subfloor, panels installed sideways.

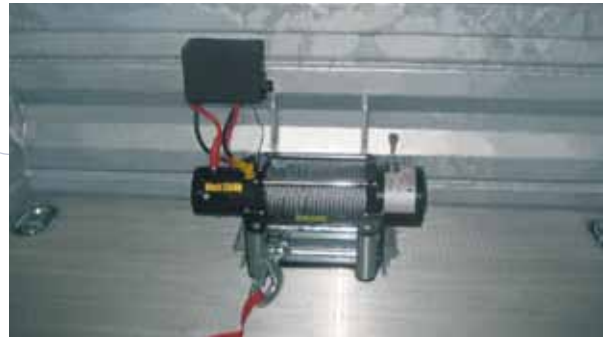

Electric winch mounted on floor.



Height adjustable drawbar, coupling height max. 1100 mm.

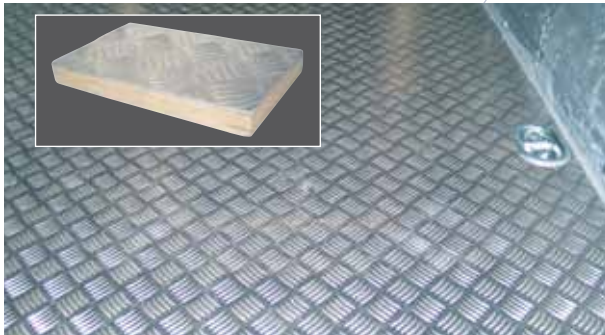

Wood floor covered with aluminum sheeting.

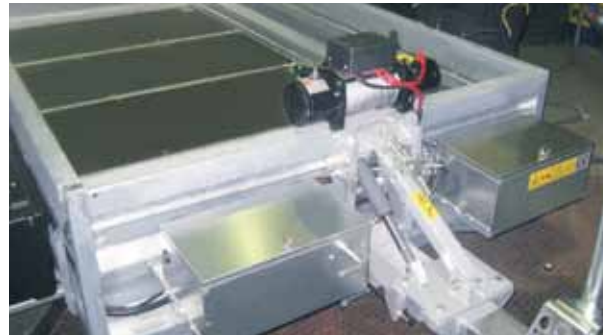

Electric winch mounted on side panel, the winches can be equipped with remote control.



Height adjustable drawbar with DIN towing eye and reinforced support wheel.



Custom aluminum fender.



Hand winch.



Support rail for transporting stone with a locking bar.



Raised side panels made of aluminum with sliding tarp.



With the Miniliner sliding cover, the roof and side walls can be moved forward.

## Other lowerable trailers and supplementary models

The lowerable trailer is available in various sizes. The box can be equipped with a polyurethane cover or you can use a solid box body. Here you will see a small selection of products from our wide range of products. The continuous development of our trailers and box bodies is just as natural as the manufacturing of individual custom solutions.



PT35 box body with generator for supplying power.



Thanks to the sliding tarp on top, you can raise a loaded lifting platform all the way to the top.



Tarp and bow box with sliding roof tarp and sliding side tarps.



Custom solutions for inner-company transport.



Easy to load using a hand pallet truck.



Shopping cart transport.



Tarp and bow with 45° angle in front.



Tarp and bow fastened in the corners using cords.



Trailer with wider side panels in the back and a longer loading ramp.



Tarp roller on the rear of the trailer (power roller).



Inside view of tarp and bow with 45° angle in front.



Stable bolted aluminum tarp bow, removable, can be inserted into the corners.



Interior LED lighting (12 or 24 Volt) for tarp frame and box bodies.

## The Vario-Liner with the lowerable loading area

With the Vario-Liner, we are following the idea of lowerable loading area. This concept was developed for vehicles with a maximum permissible weight of 3.5 tons. The model LR 35 to LR 40 lowerable vehicles with box bodies can be towed with a Class B driver's license. The newly developed lowerable vehicle model LR 35 is designed for vans with a maximum permissible weight of 3.5 or 4 tons. The 3.5 ton model can be towed with a Class B driver's license.

We offer completely new transport capabilities in this vehicle category. When the loading area is lowered flat to the ground, the platform is lowered horizontally and continuously. For example, you can roll palletized goods onto the loading area with a hand pallet truck or a manually operated electric fork lift. Problem-free and safe loading is also guaranteed with a hand truck, cleaning machine, or a fork lift. This also eliminates the need to use a correspondingly long loading ramp. The advantages are clear – quick loading and unloading in the tightest spaces, highly flexible due to the exchange system, and ergonomic handling of the load. High efficiency in small vehicle classes.

It is just as easy to operate the compactly designed vehicle as it is to load it. The box body is lowered completely or pumped back up again by an electro-hydraulic pump. The lifting and lowering procedure takes only few seconds. The box is secured using hydraulics only so that no further intervention by the operator is necessary. Just bring it into driving position and drive off.



The Vario-Liner is lowered to the ground.



There is a lot of storage space inside the Vario-Liner.

## The Vario-Liner offers many advantages

Our Vario-Liner offers **many advantages at a glance:** fast and safe loading, Class B driver's license for the Vario-Liner 35, high load capacity, no Sunday driving ban, green emission class sticker, high degree of flexibility, exchange system.

### Door

The door is easy to operate and can be closed securely.

### Material

The box body is manufactured professionally and from high quality materials.

### Wheel well

The wheel well is made of high quality materials and serves to protect the wheels.

### Loading area height

Lowered, 80 mm.

### Box body

The box body can be completely horizontally lowered until flat on the ground to make it easy to load using roller containers.

### Loading ramp

The loading ramp is lowered to the ground, which makes it easy to drive the goods on to the trailer.





Chassis of the KST trailer without the frame for the bed.



The KST-trailer with an exchangeable box.



Versatile use of the trailer.



The platform of the trailer can be parked and stay on-site with the goods.



A loaded KST trailer in driving position.



The spare tire is securely fastened.

## The KST trailer can be used in a variety of different areas

The special exchange system of the KST35 allows different load carriers to be mounted. Ground-level loading and the highest possible flexibility characterize this system. The platform can be lowered and parked. It is now possible to load the trailer from the side as well.

Various types of load carriers such as transport platforms, tool containers, or box bodies turn this trailer into an all around system.

Platform size: ..... 2,850 x 1,520 mm  
 Max. permissible weight: ..... 3,500 kg  
 Load capacity: ..... max. 2,700 kg  
 Other sizes ..... available upon request

Other sizes and custom-made products available upon request.



## The KST-trailer and its advantages

We develop purpose-oriented ideas for you to obtain the easiest possible operation. The handling of this KST trailer was designed with safety in mind. All operating functions can be controlled centrally. Variety of uses for the trailer.



### Lowerable

The trailer can be lowered to ground level for easy loading.

### Loading ramp

The trailer is safely loaded using the loading ramp.

### Loading area height

Lowered, 80 mm.

### Loading

Lifting platforms or similar equipment can be easily rolled on to the trailer.

### Operation

Electro-hydraulic operation to raise and lower the loading area.

### Loading area

The platform on the trailer can simply be parked and left on-site with the goods.



The trailer can be lowered completely to the ground. You can sell from 3 sides.



The stall trailer can be used in various areas. 4 open sides.



A lowered PT stall trailer with the side panels raised for use as a beverage or sales stall.



A door is built into the rear of the stall trailer.



The lowerable stall trailer has a roof and protected in the back by a wall.



The stall trailer can be manufactured in different lengths and sizes.

## Our stall trailers are top-of-the-line products

Our stall trailers are valuable, high quality, top-of-the-line products whose appealing appearance will not only delight you, but also your customers.

Lowering the trailer makes it easy to load. Another advantage: you can sell your goods at eye level and cater to the needs of your customers. By selling „at eye level“ with the customer, you can increase your sales by up to 30%! The trailer can be loaded using a trolley or CC containers thanks to the ability to lower it to ground level. This also allows you to sell your goods right from the means of transport. The setup time is reduced.

Due to the special independent suspension and the Sachs coil springs, delicate goods such as fruits, strawberries, tomatoes, etc., are transported especially gently. Thanks to numerous options, the PT18 and PT35 can become your own special vehicle. We manufacture every stall trailer specially according to our customer's needs and in direct agreement between the manufacturer and customer.

Other sizes and custom-made products available upon request.

**AT EYE LEVEL WITH THE CUSTOMER!  
– MORE SALES BY SELLING  
AT GROUND LEVEL –**

## The stall trailer and its advantages

Ultra-modern technology, quality-tested materials, and technical ingenuity make the Heimann stall trailers top-of-the-line products. Their handling was designed with safety in mind. All operating functions can be controlled centrally. Heimann develops purpose-oriented ideas for you to obtain the easiest possible operation.

### Drawbar

Rotatable bearings to allow lowering to ground level while still hitched to the towing vehicle.

### Interior equipment

The counter can also be set at an angle.

### Loading

Can be loaded using roller containers and pallet trucks.

### Loading area

The loading area is raised and lowered hydraulically by a manual pump. Loading area height when lowered, 80 mm.



### Tarp

It is easy to stow the tarp.

### Goods

The goods can simply be rolled onto the lowered loading area of the trailer.

### Box

Sales doors on four sides, all of which are made of an aluminum square tube frame covered by aluminum sheeting.

### Tailgate

600 mm high, max. load capacity of up to 2500 kg depending on the design.



FOXX deposit tipper.



City semi-trailer with a total weight of up to 14 tons.



Roller tipper trailer.



AKFV deposit tipper unit can be widened, up to 12 tons.



Deposit tipper trailer.



Van tipping box.

## Our product range

- Tiltable trailers ..... ■
- Lowerable vehicles ..... ■
- Lowerable trailers ..... ■
- Stall trailers ..... ■
- Van tipping boxes ..... ■
- Tipping trailers ..... ■
- Deposit and roller trailers (FOXX) ..... ■
- Deposit and roller units ..... ■
- City semi-trailer ..... ■
- Motorcycle trailers ..... ■
- Platform trailers with fifth wheel ..... ■
- Trailers with extendable drawbars ..... ■



Heimann Fahrzeugbau GmbH & Co. KG  
 Zeppelinstraße 9 · 48301 Nottuln / Germany  
 Tel. +49 25 09 / 993 92-0  
 Fax +49 25 09 / 993 92-27  
 info@heimann-fahrzeugbau.de  
 www.heimann-fahrzeugbau.de

Provided by:

The images shown may contain special accessories and may not match the base model. We reserve the right to make technical changes.