



cmc

THE SPECIALIFT

Une gamme à la hauteur de chaque situation

Les plates-formes automotrices sur chenilles CMC peuvent fonctionner même dans les situations les plus extrêmes, alliant polyvalence, fiabilité et simplicité d'utilisation.

Depuis plus de 20 ans, nous construisons nos plates-formes aériennes en nous demandant qui les utilisera chaque jour. C'est ainsi que nous avons réussi à créer une gamme capable de répondre à différents besoins et de résoudre tout problème d'utilisation par les utilisateurs. Une série de produits aux caractéristiques différentes, équipements techniques et dimensions, mais tous capables d'offrir des performances uniques en termes de polyvalence, simplicité d'utilisation, robustesse, fiabilité. Une qualité qui, associée à un service efficace d'assistance technique et de conseil après-vente, a fait de la marque CMC une référence dans son secteur au niveau international, avec un marché qui s'étend aujourd'hui à 36 pays sur les cinq continents.

- **S13F** entièrement hydraulique à bras télescopique avec 2 extensions plus pendulaire 90° (jib).
- **S15** géométrique avec double pantographe et bras télescopique avec 1 extension plus pendulaire 90° (jib).
- **S15F** géométrique, entièrement hydraulique avec 1 pantographe plus 1 bras télescopique à extension et pendulaire 90° (jib).
- **S18F** entièrement hydraulique avec 1 pantographe plus bras télescopique avec 2 extensions et pendulaire 90° (jib).
- **S19E** géométrique avec double pantographe et bras télescopique avec 1 extension plus pendulaire 90° (jib).
- **S19N** double pantographe et bras télescopique avec 1 extension plus pendulaire 90° (jib).
- **S19HD** auto-chargement sur la remorque avec 1 pantographe, bras télescopique.
- **S22HD** auto-chargement sur la remorque, 1 pantographe avec bras télescopique plus pendulaire 90° (jib).
- **S23** géométrique avec double pantographe, bras télescopique et pendulaire 90° (jib).
- **S25** avec double bras télescopique et pendulaire 90° (jib).
- **S28** avec double bras télescopique et pendulaire 90° (jib).
- **S32** avec double bras télescopique et pendulaire 90° (jib).
- **S41** bras entièrement télescopique plus pendulaire 90° (jib).

aussi dans les modèles:



S13F

CMC



CAPACITÉ MAXIMALE

230 KG   
80 KG 



PRESTATIONS

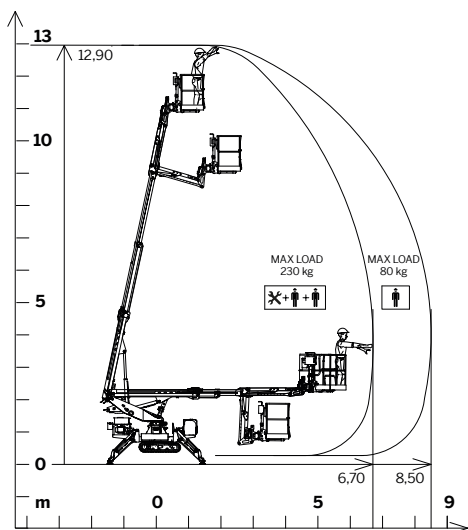

12,90 m



8,50 m



230 Kg



1,4x0,7x1,1 m



+/- 90°
optionnel



+/- 178°
(356° pas continu)



kg

1565 Kg



CAPACITÉ MAXIMALE

230 KG   



PRESTATIONS

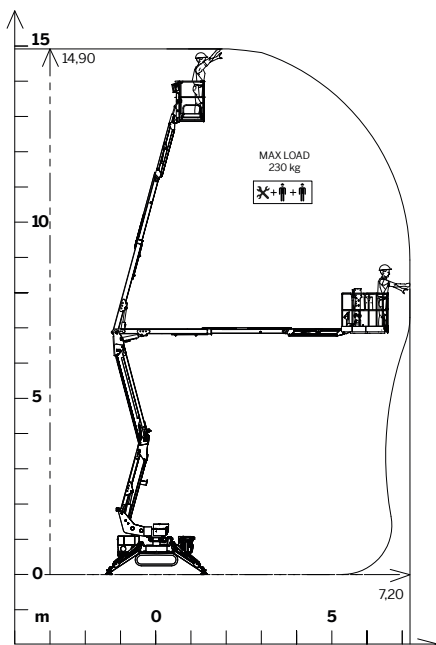

14,90 m



7,20 m



230 Kg



1,4x0,7x1,1 m



+/- 178°
(356° pas continu)



kg

1820 Kg

S15F

CMC



CAPACITÉ MAXIMALE

200 KG



PRESTATIONS

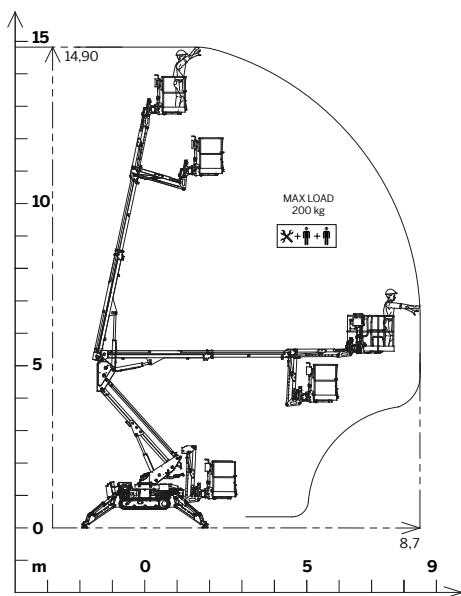

14,80 m



8,70 m



200 Kg



1,4x0,7x1,1 m



+/- 90°
optionnel



+/- 178°
(356° pas
continu)



2378 Kg

CMC

S18F



CAPACITÉ MAXIMALE

230 KG  +  +  + 
80 KG 



PRESTATIONS

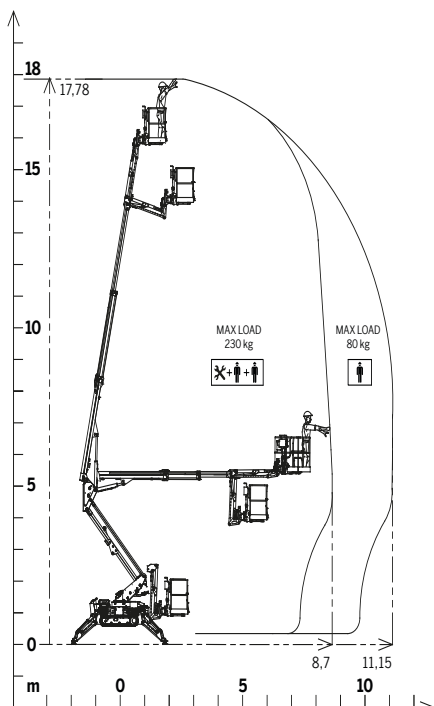

17,92 m



11,15 m



230 Kg



1,4x0,7x1,1 m



+/- 90°
optionnel



+/- 178°
(356° pas continu)



2495 Kg

S19E

CMC



CAPACITÉ MAXIMALE

200 KG   



PRESTATIONS

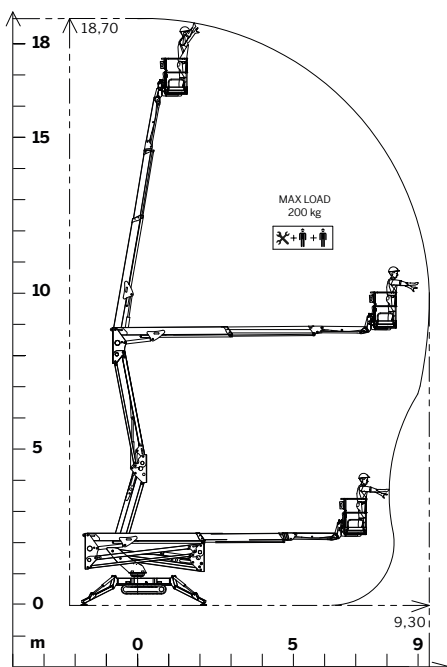

18,70 m



9,30 m



200 Kg



1,4x0,7x1,1 m



+/- 178°
(356° pas continu)

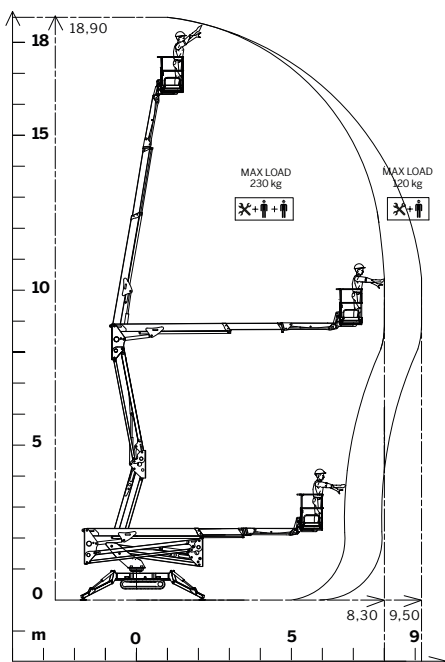

2545 Kg

cmc**S19N****CAPACITÉ MAXIMALE**
 230 KG   
 120 KG  
**PRESTATIONS**

18,90 m



9,50 m



230 Kg



1,4x0,7x1,1 m

 +/- 178°
 (356° pas continu)
**kg**

2435 Kg

S19HD

CMC



CAPACITÉ MAXIMALE

200 KG  +  + 
80 KG 



PRESTATIONS

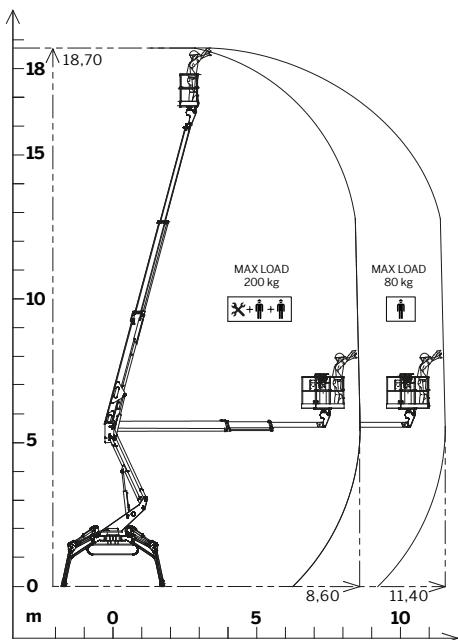

18,70 m



11,40 m



200 Kg



1,4x0,7x1,1 m



+90°/-87°
optionnel



+/-355°
(710°
continu)



2666 Kg



CAPACITÉ MAXIMALE

230 KG + + +
80 KG



PRESTATIONS

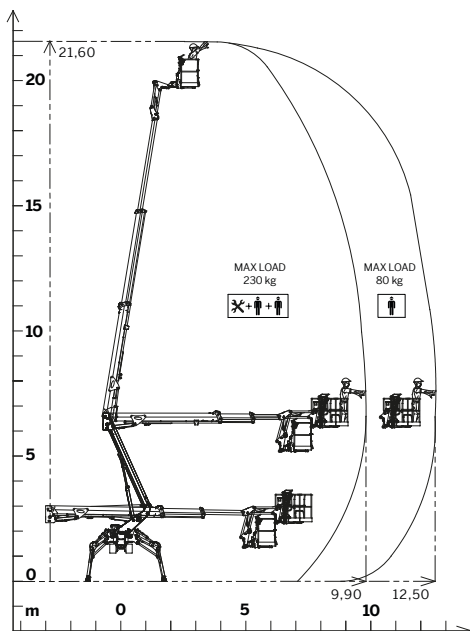

21,60 m



12,50 m



230 Kg



1,4x0,7x1,1 m



+/-90°
optionnel



+/-355°
(710°
continu)



3008 Kg

S23

CMC



CAPACITÉ MAXIMALE

200 KG   



PRESTATIONS

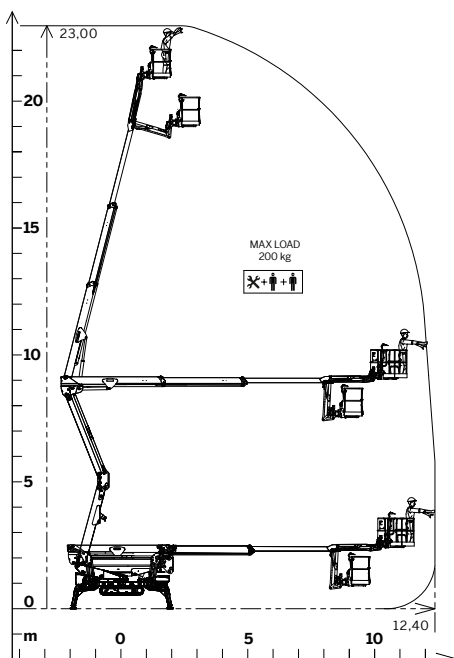

23,00 m



12,40 m



200 Kg



1,4x0,7x1,1 m



+/-90°
optionnel



+/-355°
(710°
continu)



2865 Kg



CAPACITÉ MAXIMALE

230 KG + + +
80 KG



PRESTATIONS

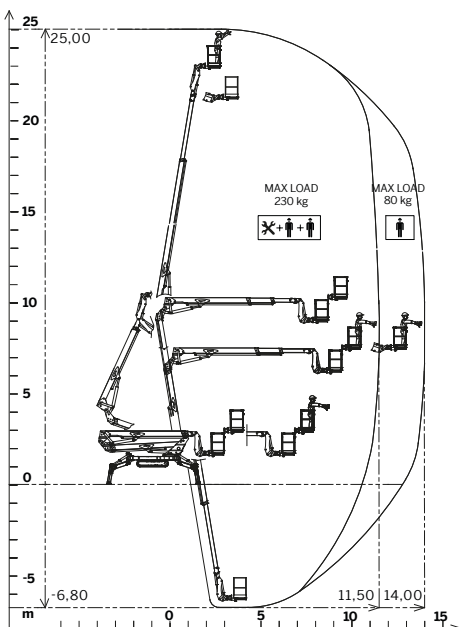

25,00 m



14,00 m



230 Kg



1,7x0,7x1,1 m



+/-90°



+/-200°
(400°
continu)



3896 Kg

S28

CMC



CAPACITÉ MAXIMALE

230 KG + + +
80 KG



PRESTATIONS

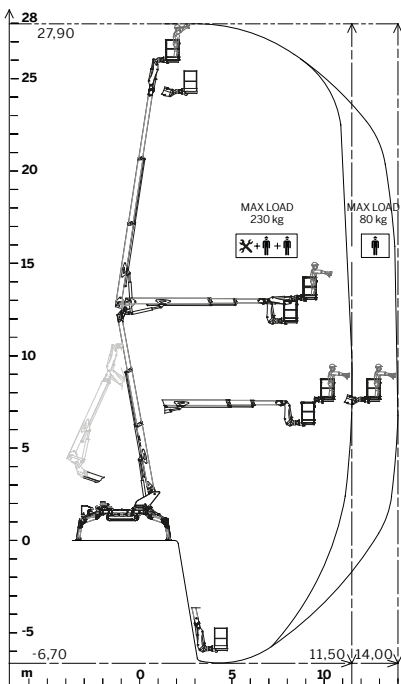

27,90 m



14,00 m



230 Kg



1,7x0,7x1,1 m



+/-90°



+/-200°
(400°
continu)



4134 Kg



CAPACITÉ MAXIMALE

220 KG
 120 KG



PRESTATIONS

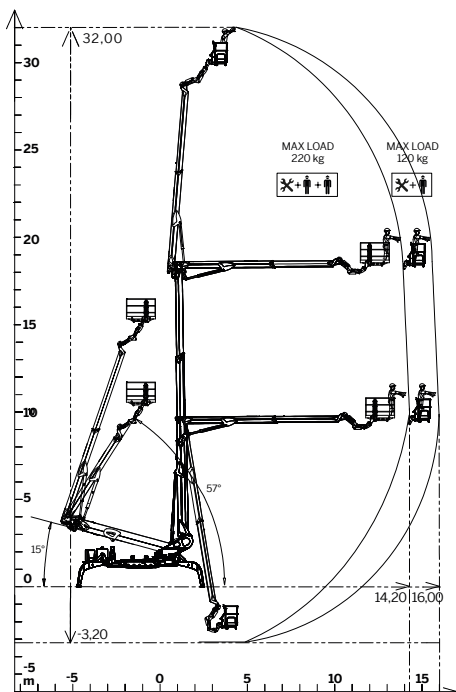

- 32,00 m

- 16,00 m

- 220 Kg

- 1,7x0,7x1,1 m

- +/-90°

- +/-200°
(400° continu)

- 7240 Kg

S41

CMC



CAPACITÉ MAXIMALE

200 KG   



PRESTATIONS

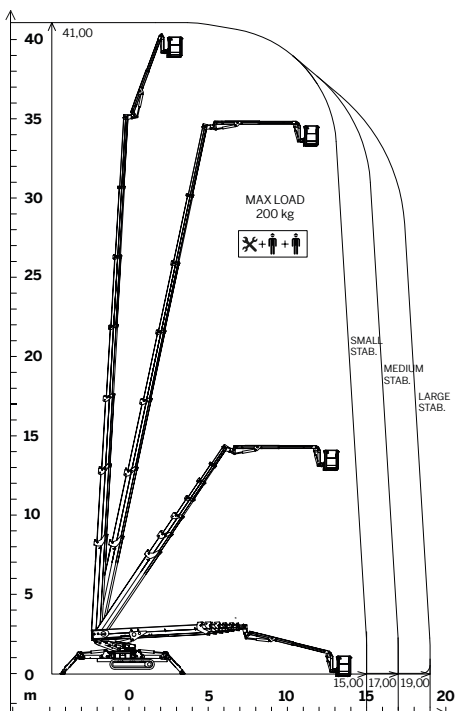

41,00 m



19,00 m



200 Kg



2x0,8x1,1 m



+/-90°



360°
continu



12500 Kg



*Cleaning equipment · trailers
handling equipment*

Ninoofsesteenweg 19 A
1570 Vollezele

info@vddcenter.be
www.vddcenter.be
054 33 11 42